

Film Packaging Perforation Cutter for Paste Products

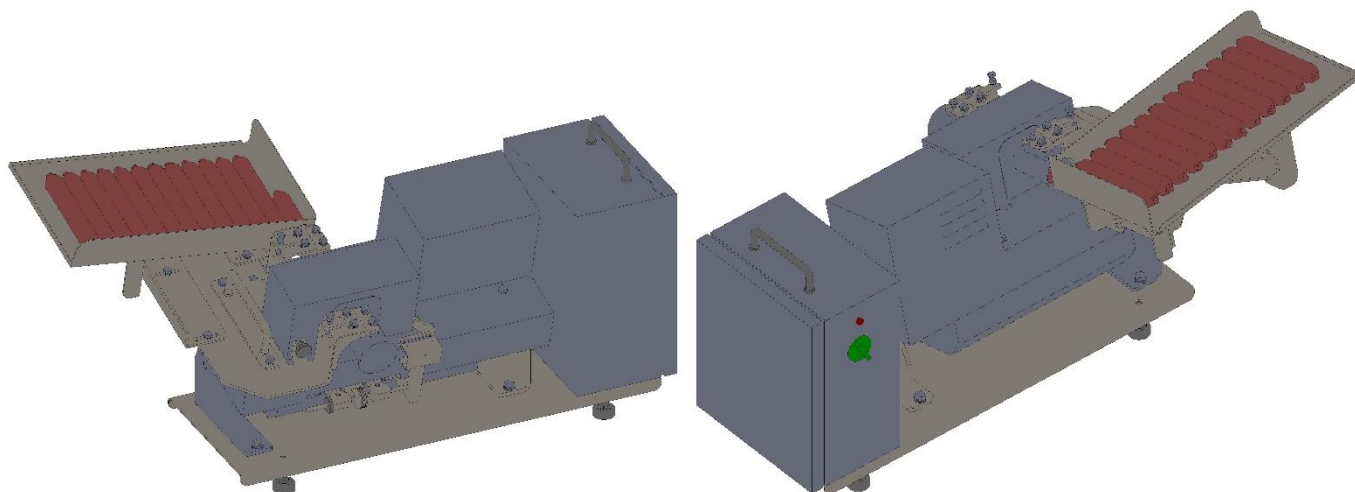

OVERVIEW : This device is utilized in food factories and similar settings to swiftly and effectively create perforations in packaging film for paste products, facilitating easy removal of the film.

- The device's cutter safety cover and blade are simple to dismantle and clean, ensuring hygiene standards.
- An interlock mechanism ensures the motor operates solely when the cutter safety cover is in place.
- Featuring a labyrinth structure, the cutter drive shaft effectively blocks water infiltration.
- Adjusting cutter spacing is straightforward with the provided adjustment dial.

SPECIFICATIONS:

Compatible sizes	Φ28 to Φ16 (Other sizes can be accommodated by replacing parts sold separately)
Processing speed	Approximately 30 pieces/minute
Power supply	60W 3-phase 200V (or single-phase 100V)
Safety cover	With interlock (waterproof)
Material	Exterior stainless steel (SUS304) Bearing stainless steel (SUS304)

※Specifications are subject to change without notice for quality improvement.

※According to the requirement, other dimensions can be quoted than those listed above.

Sales Agents:



Aiming for Harmony between People and Work

Daishin Co., Ltd

2635 Isagai, Higashiyoka-cho, Saga city, Saga, 840-2223, Japan.

TEL +81952-45-5131 / FAX +81952-45-5132

E-mail saga@daishin-sa.co.jp

URL <https://daishin-sa.co.jp>

